



SB PUMPS

AN ISO 9001 CO

*The
Pump People*

**Series -TV - 3
Model - SBSL404TV**

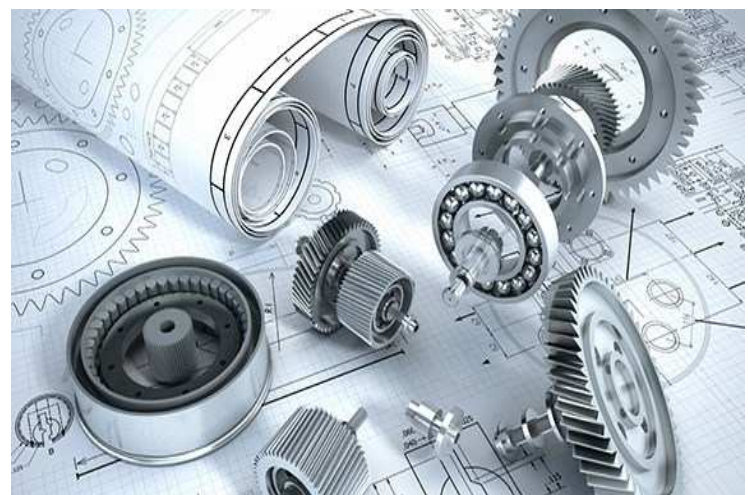

**Twin Volute
Slurry submersible Pump
Built Rugged and Tough**





Applications of SB make Slurry submersible Pump



Bottom Ash/Fly Ash, Coal Washery, Mill Scale, Coal Dust, Coke pits, Mines Dewatering, Boiler Blow Down, Hydro Power Station Slurry, Silt – Removing, Ocean sand mining, Thick Mud. Lime Slurry, Cement Slurry, Coal Slurry , Ore Slurry, Dredging, De - silting etc.

Special Features:-

- Agitator attached directly to the extended rotor shaft.
- Discharge up to – 220 M³/Hr.
- Head upto – 38 Mtr.
- Solid Handling Size up to 38 mm.
- Delivery size up to 100 mm.
- Max. Submergence upto 28 Mtr.
- Double Cage Rotor.
- Max. Slurry Temp – 90 Deg.
- 4 pole Motors.
- Safety factor 1.35.
- Adjustable Wear Plate and impeller.
- Max. Specific Gravity upto - 2.8 Kg/L.
- Special Double Mechanical Seal, arrangement
- Max. Horizontal Pumping Distance 750Mtr.
- Material of Construction, Ni – Hard.



All **SB Vertical slurry twin volute submersible pumps** are designed specifically for abrasive slurries and feature robust design with ease of maintenance. The pump range is one of the strongest, toughest and most reliable pumps in the market. Ultimate design to operate [under fully submerged or partially submerged for maximum pumping.](#)

The SB twin volute slurry submersible pumps are easy to install, and feature a cantilever design without submerged bearings or shaft seal. The bearing assembly with double protection sealing arrangement prevents ingress of slurry. The materials used are the very best available, providing both excellent wear properties and corrosion resistance. Wear parts are available in a variety of different materials and fully interchangeable. Semi-open and closed impellers are available to suit any pumping needs.

The wet-end parts are designed for the toughest application and the longest wear life, the Twin volute and generous solids passages through the pump ensure a safe and clogless operation. Standard pumps are supplied with wear resistance like High Chrome white iron alloy, Ni – Hard....

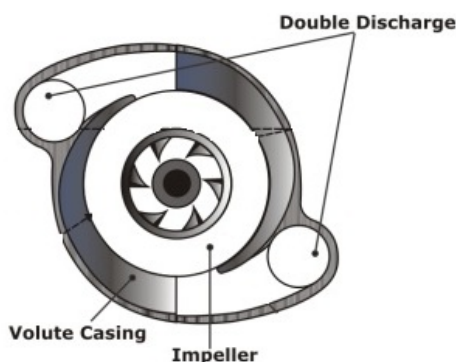

This figure show how the thrust is balanced by the Twin-Volute with 180 degrees opposite discharge outlets.

GA DRWAING OF SB MAKE TWIN VOLUTE SLURRY SUBMERSIBLE PUMP

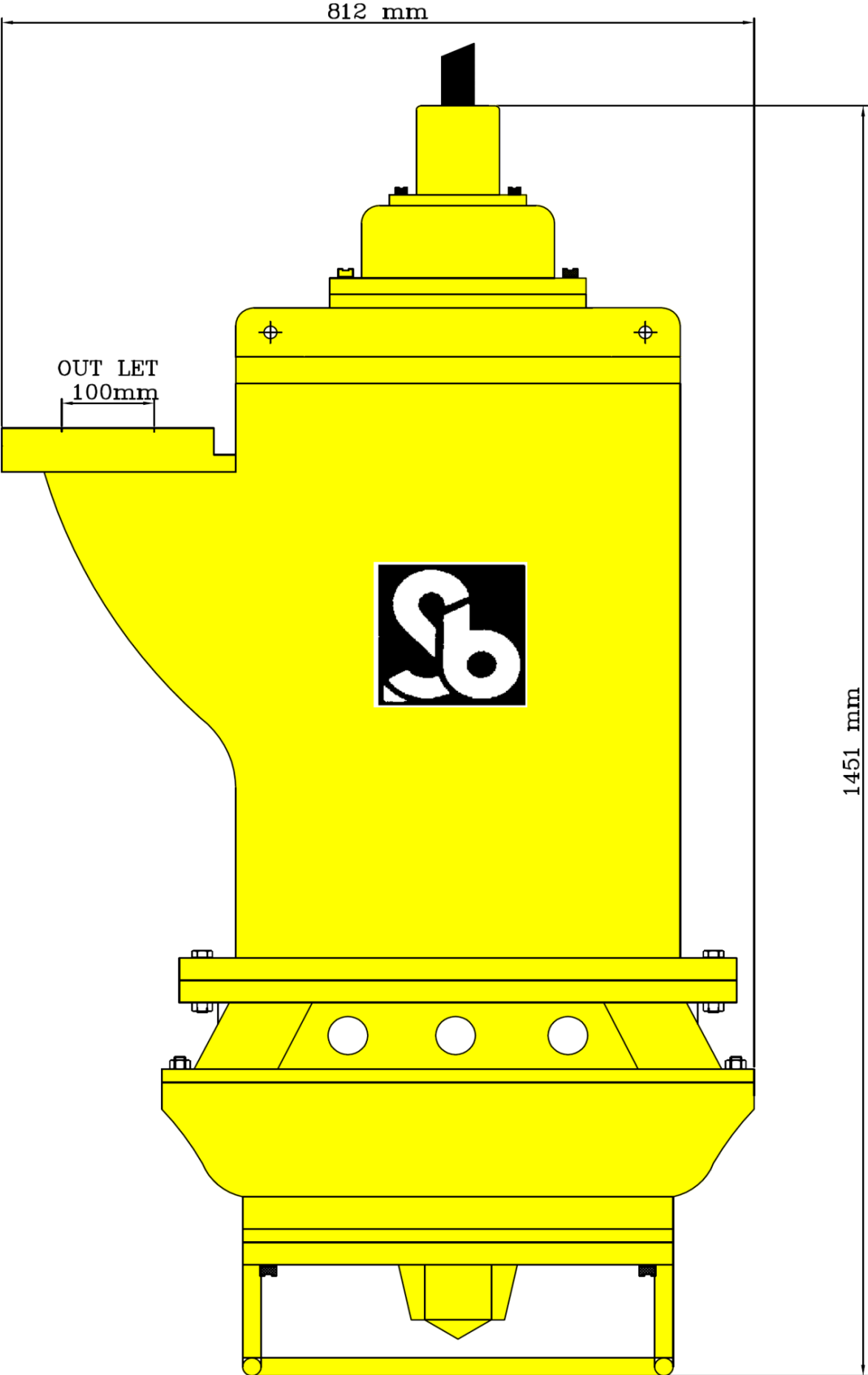

CROSS SECTIONAL VIEW OF SB MAKE SLURRY SUBMERSIBLE PUMP

Four Pole continuous rated motor which is moisture proof, winded with superior quality of copper and dual Coated insulation of class F/H thermal .

High Grade double cage rotor which gives Higher torque, large cross section and low Resistance resulting in a high efficiency

Heavy duty over size bearings are being Provided.

Double Mechanical seal in back to Back arrangement, enclosed in a oil Chamber and further protected by Leap seal. Both the faces located In oil bath, both faces are lubricated by The oil, it ensure a longer life of the Product and a stable sealing effect fitted in **pressure free zone**

Impeller, casing, wear plate are made Upof Ni – Hard, Hi chrome which have Excellent abrasion resistance for Tough application

Unique designed agitator is Provided to resuspended Settled solid, assisting the Pump to transfer a high percentage of Settled solid particals, due to perfect design, It effectively works under dense slurry

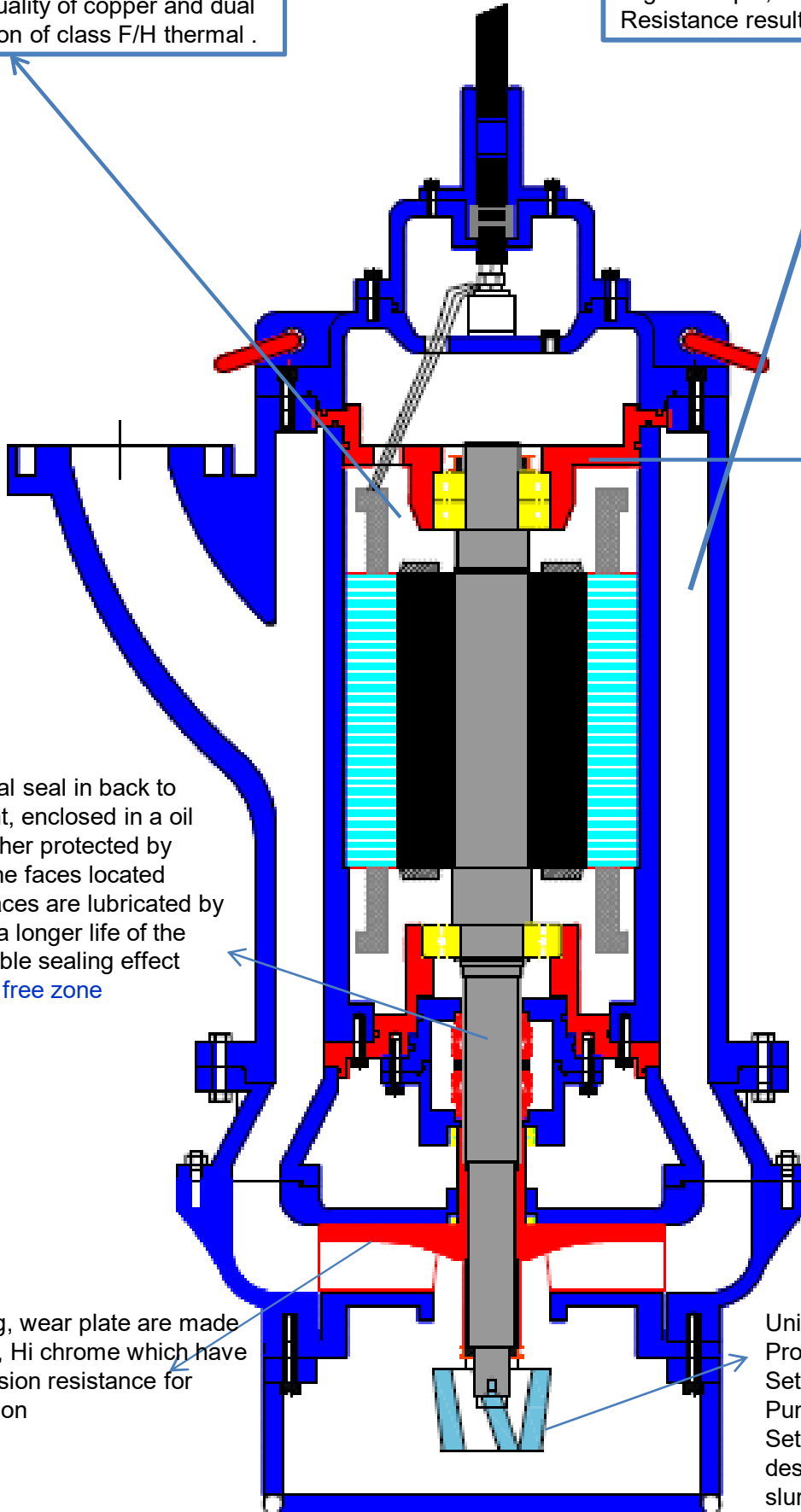

PERFORMANCE CURVE

Performance Curve MODEL – SBSL404TV Series - TV - 3

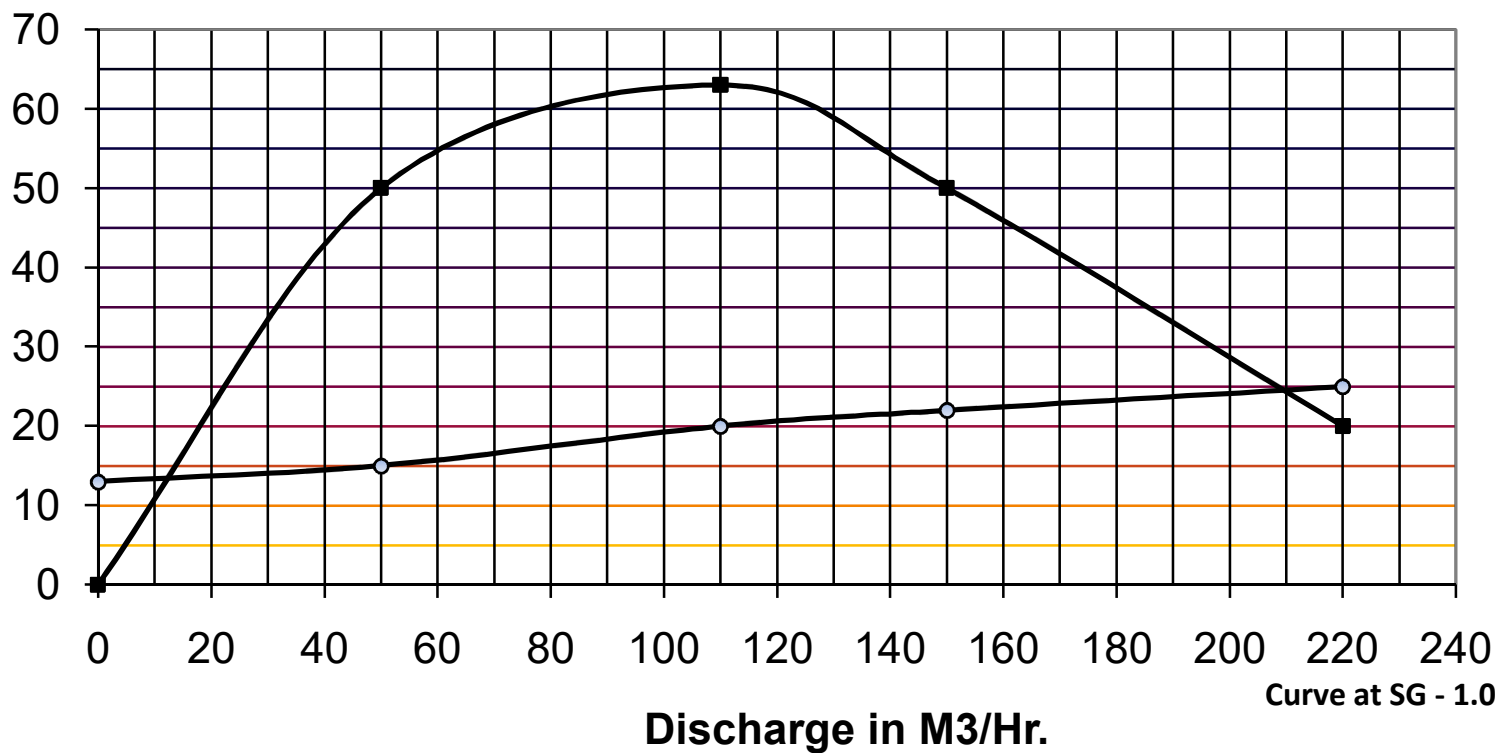
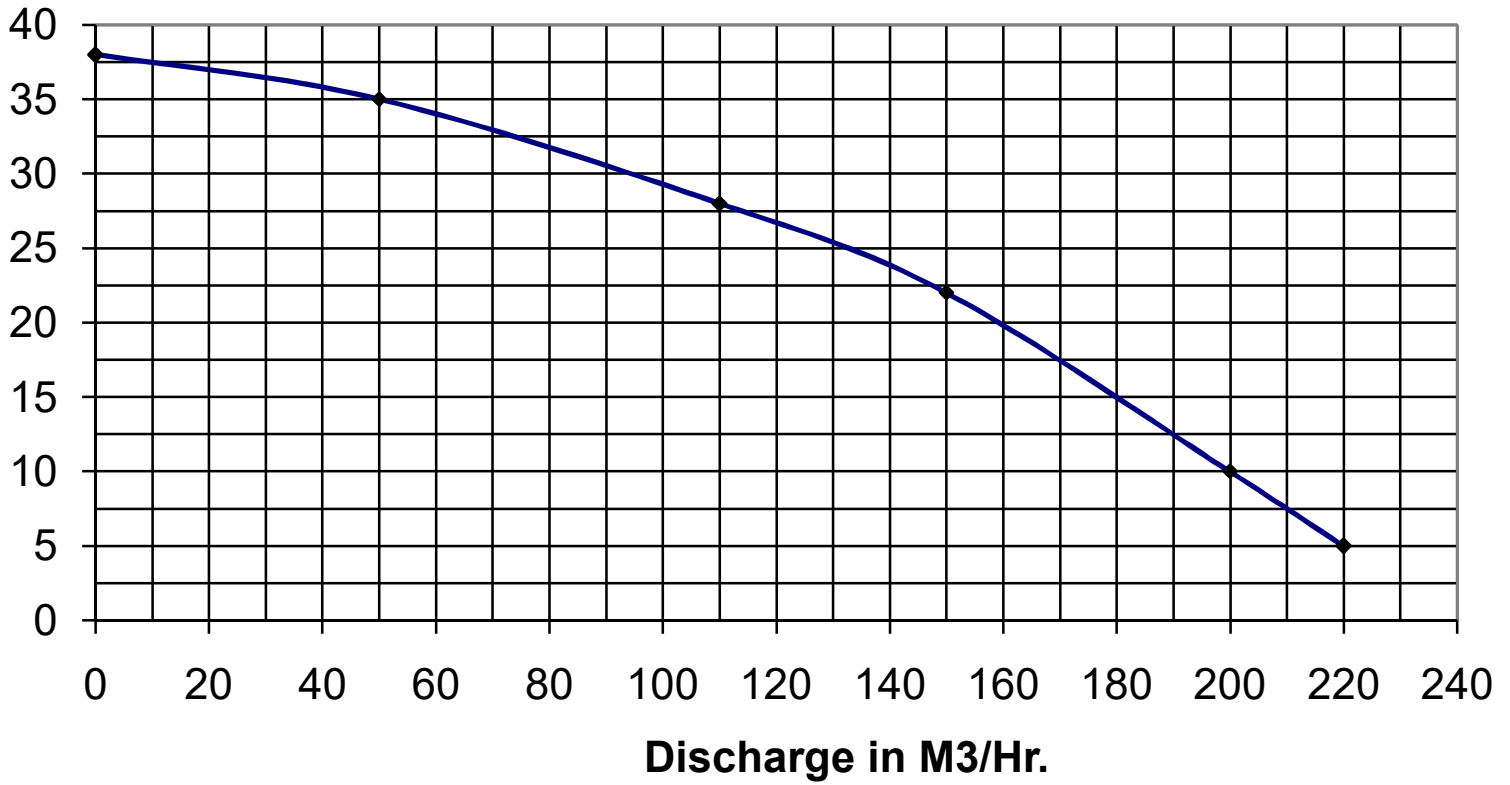

Accessories for Slurry Submersible Pumps.

❖CONTROL PANNEL:-

Unique Control Panel consisting of DOL starter with Motor Protection Relay, Amp. Meter, Volt Meter, with Selector Switch, 3 Phase Indicator, Start – Stop Indicator, ON–OFF Push Button, ELR with CBCT, with Float Switch, Incoming MCB/MCCB. Control panel can be supplies as per client specification.



❖Heavy Duty Slurry Discharge Hose:-

▪Specially designed Slurry Discharge Hose Wire embedded good wear Resistance, Nylon Reinforced suitable for discharge pressure of 10kg/CM2, with rubber molded flange.



❖Lifting Chain:-

▪Heavy duty SS 304 Grade Chain for Lifting and Installation of Pump. 500mm Length.

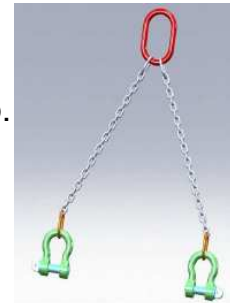

Manufacturer

SB PUMP INDUSTRIES

Plot No.30 Industrial Area Richhai Jabalpur – 482010 – MP – INDIA.

Tele/Fax - +91 – 761 – 2330221 .email – info@sbpumpsindia.com

Web – www.sbpumpsindia.com